

The Deepwater Horizon Blowout An Update – Drill string Buckling and Shearing

By
Glen Stevick, Ph.D., P.E.
Berkeley Engineering And Research, Inc (BEAR)

May 27-29, 2016
Society of Forensic Engineers and Scientists (SFES)
Maritime Seminar, Emeryville, CA

Abstract: On April 20, 2010, the Deepwater Horizon mobile offshore drilling rig experienced a blowout while abandoning a well (after cementing operations). The primary piece of equipment used to stop a blowout in progress is the blowout preventer (BOP). This 6 story tall, 400 ton piece of equipment is located on top of the well head on the ocean floor, 5,000 feet below sea level on the Macondo well. The BOP contains five dual ram like devices to control a well which are described in numerous reports. The backstop device if all fails is the blind shear ram (BSR) that can both shear drill pipe that may be in the well and seal the well. **The Chemical Safety Board (CSB) in approving its final report last month (April 2006) claimed the BSR “failed to seal the well because drill pipe buckled for reasons the offshore drilling industry remains largely unaware of . . .”** Pipe buckling due to high internal pressure when one end of the pipe is open has been known in the oil production industry (upstream) and described in the open literature since the 1960's. However, it is an issue that must be considered in shearing drill pipe in an emergency along with upper bound pipe shear properties and the friction forces that develop in closing a BSR during a blowout. All three of these issues have been inadequately addressed in the industry and are discussed in detail in this paper.

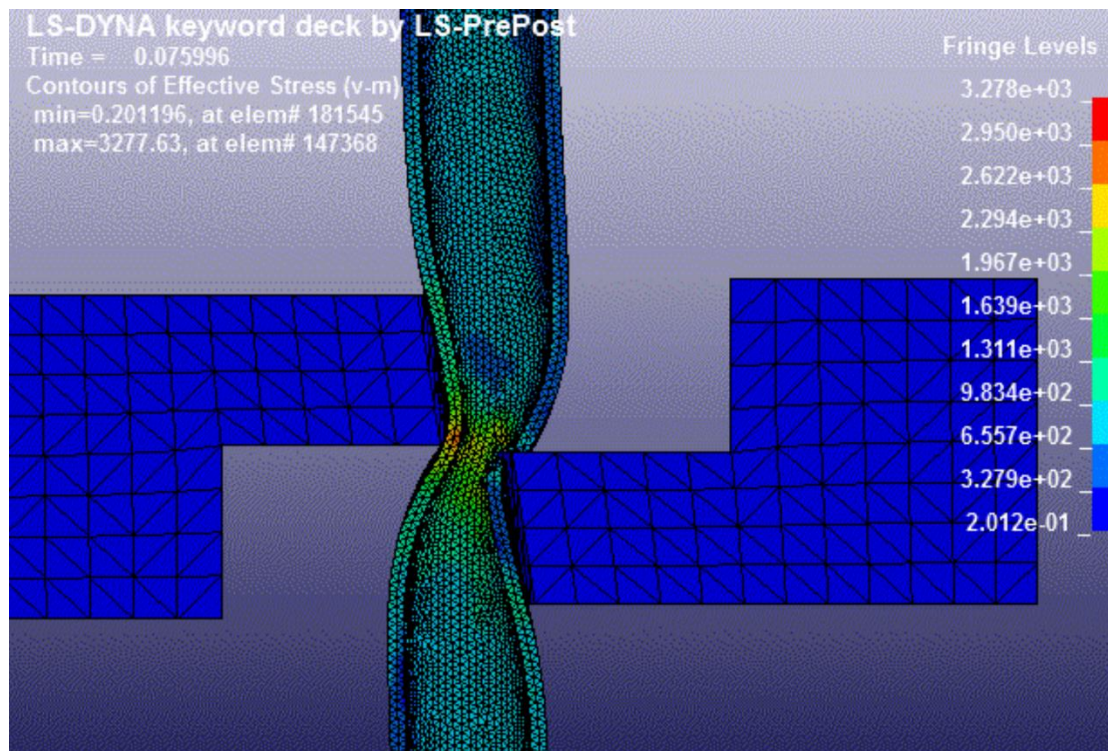

Finite element simulation of a BSR shearing drill pipe by BEAR in analyzing the Hercules blowout in the Gulf of Mexico, July 23, 2013.

INTRODUCTION

The Deepwater Horizon (DWH) was a billion dollar rig capable of propelling itself to a drilling site and dynamically positioning itself to keep station at the drilling site. The accident occurred while the DWH was at the Macondo well site located approximately 50 miles off the coast of Louisiana in the Mississippi Canyon region of the Gulf of Mexico. On April 20, 2010, the DWH experienced a blowout after completing cementing operations to abandon the well. Deepwater, high production wells, are commonly abandoned after drilling for many months to allow transportation and processing infrastructure to be built before production begins. The primary piece of equipment used to stop a blowout in progress is the blowout preventer (BOP). This 6 story tall, 400 ton piece of equipment is located on top of the well head on the ocean floor, 5,000 feet below sea level on the Macondo well. The BOP contained five dual ram like devices to control a well which are described in numerous reports:

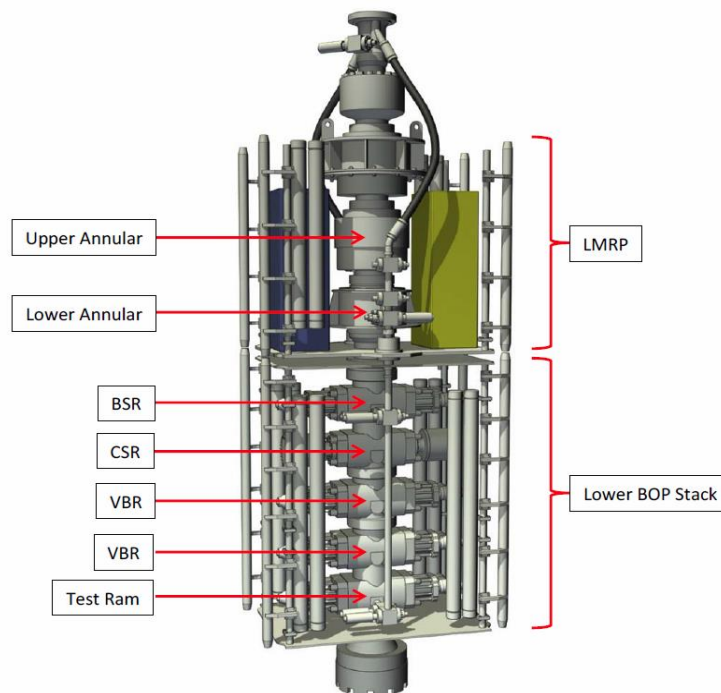

Figure 1. The DWH BOP, showing the position of annulars and ram valves.¹

¹ Perkin, G.S., Expert Report, August 26, 2011. Cited image source: Engineering Partners International, LLC.

The backstop device if all fails is the blind shear ram (BSR) that can both shear drill pipe that may be in the well and seal the well. The Chemical Safety Board (CSB) in approving its final report last month (April 2006) claimed the BSR “failed to seal the well because drill pipe buckled for reasons the offshore drilling industry remains largely unaware of . . .”² Buckling did cause the drill pipe to be off-center and jam open the BSR as shown in Figure 2 below:

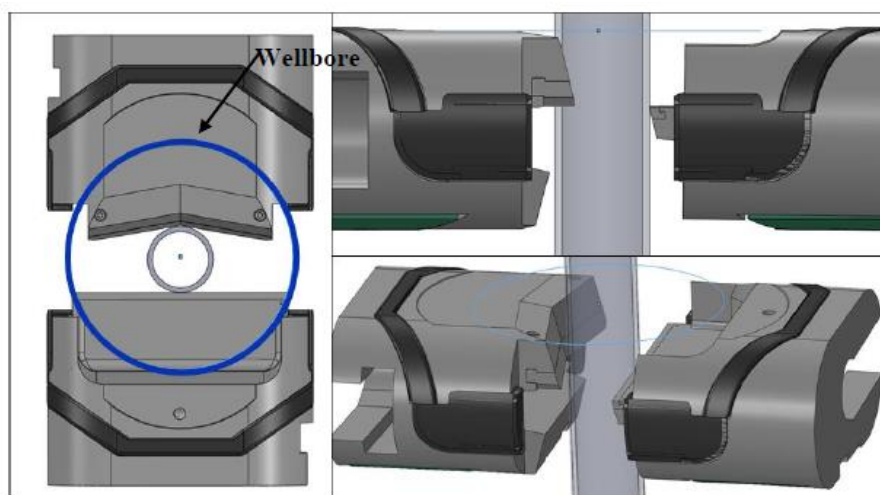

Figure 2. Model of the DWH BOP BSR from the Det Norske Veritas (“DNV”) report.³

Pipe buckling due to high internal pressure when one end of the pipe is open has been known in the production side of the oil industry (upstream), and described in the open literature, since the 1960’s. The CSB traditionally has investigated chemical and oil refining accidents (downstream) where pipes are virtually never under high pressure with an open end; there is always an elbow, flange, valve or other device the fluid pressure will bear against, causing a pressure induced tension in the pipe and, thus, precluding buckling. However, it

² <http://www.csb.gov/csb-board-approves-final-report-finding-deepwater-horizon-blowout-preventer-failed-due-to-unrecognized-pipe-buckling-phenomenon-during-emergency-well-control-efforts-on-april-20-2010-leading-to-environmental-disaster-in-gulf-of-mexico/>.

³ Det Norske Veritas, Final Report for United States Department of the Interior Bureau of Ocean Energy Management, Regulation, and Enforcement, Forensic Examination of Deepwater Horizon Blowout Preventer, Contract Award No. M10PX00335, Volume I Final Report, Report No. EP030842, 20 March 2011 (“DNV Report Vol. I”), Figure 132.

is an important consideration in shearing drill pipe in an emergency along with upper bound pipe shear properties and the friction forces that develop in closing a BSR during a blowout. All three of these issues have been inadequately addressed in the industry and are discussed in detail in this paper.

DRILL STRING BUCKLING

Following the fire and explosion of the *Deepwater Horizon* ("DWH"), it was known that the drill pipe pressure at the rig was approximately 6,000 psi and climbing.⁴ It was also known 2,500 *ft* of 5.5 *inch* drill pipe extended below the BOP and another 800 *ft* of 3.5 *inch* pipe referred to as a "stinger" section, extended below the 5.5 *inch* diameter drill pipe. The stinger was open on the end.

To properly assess which and in what order the BOP element should be closed, BP should have estimated the likelihood that the drill pipe in the BOP was buckled or bowed. The phenomenon of buckled or bowed pipe due to internal pressure (that would cause it to be off-center) was known, particularly in the downstream half of the oil and gas industry.⁵ Regarding buckling in general, it is virtually impossible to find a mechanical engineering design textbook that does not teach buckling.⁶ The equations "*describing critical buckling loads were derived by the great mathematician Leonhard Euler in 1757.*"⁷ Buckling equations are also given in most textbooks on well control and well completion.⁸ Buckling of the drill pipe was foreseeable and should have been considered prior to

⁴ British Petroleum Report by Bly, Appendices D and E, Sperry Sun Realtime Data.

⁵ Lubinski, A., and J.L. Logan, Buckling of Tubing Sealed in Packers, Journal of Petroleum Technology, Vol. 14, No. 6, pg 655-670, June 1962. Well Completion Design, by Jonathan Bellarby, Elsevier Science, 2009.

⁶ Mechanical Engineering Design, 1st - 7th Editions, by Joseph Shigley, McGraw-Hill, 1977-2003. Higdon, A. et al, Mechanics of Materials, 3rd Edition, John Wiley & Sons, 1976.

⁷ Grace, R.D., Blowout and Well Control Handbook, Gulf Professional Publishing, 2003, p. 291.

⁸ Drake, L.P., Well Completion Design, Elsevier Science, 2009. Firefighting and Blowout Control, by Abel, L.W., Bowden, J.R., and P.J. Campbell, Wild Well Control, Inc., Bookcrafters, 1994. Well Completion Design, by Jonathan Bellarby, Elsevier Science, 2009. Grace, R.D., Advanced Blowout and Well Control, Gulf Professional Publishing, 1994.

activating any BOP rams. The calculations would have taken less than an hour to complete and thoroughly check as shown in the attached two pages of calculations performed using S-Math.⁹

There were three compressive loads on the drill pipe as the VBR's closed from 21:47 to 21:49 on April 20, 2010: (i) pressure pushing up on the end of the drill pipe and surfaces at the 5.5 *inch* to 3.5 *inch* pipe transition, (ii) effective compression due to internal pressure and (iii) upward friction due to flow past the VBR's and upper annular. The only downward force was the drill pipe weight.

The upward load due to pressure acting on the end and transition section surfaces of the drill pipe are determined with Equation 1 in the attached calculations. The effective compression due to drill pipe internal pressure is given by Equation 2.¹⁰ Equation 3 is the 1757 buckling formula and Equation 4 is the secant buckling formula which approximates the force required to maintain a buckled shape.

The total compressive force (not including flow friction), 118 kips, is above the likely range of buckling loads for the drill pipe, 55 to 110 kips. The required load to maintain buckling is less than half that to initially buckle the drill pipe. Thus, the drill pipe should have been assumed to be off-center and subsequently held off-center by flow forces. Further, the drill pipe should have been assumed to be off-center due to the traveling block falling and the rig drifting.¹¹

⁹ <http://en.smath.info/>.

¹⁰ Lubinski, A., and J.L. Logan, Buckling of Tubing Sealed in Packers, Journal of Petroleum Technology, Vol. 14, No. 6, pg 655-670, June 1962. Well Completion Design, by Jonathan Bellarby, Elsevier Science, 2009.

¹¹ Stevick Phase I Rebuttal Report.

DRILL STRING SHEARING

Studies performed for the Mining Minerals Service (MSS) on BOP's deployed in deep water indicate a significant lack of shearing capacity and safety factor for shearing pipe. In many cases, the shear rams deployed in the Gulf were incapable of shearing the pipe being used to drill based on field testing:¹² *"If operational considerations of the initial drilling program were accounted for, shearing success dropped to three of six (50%)."* This situation directly led to the Deepwater Horizon Spill and is due in part to a significance misunderstanding of the shearing process and test data. The test data for shearing pipe is always referred to as having a huge scatter. It does have a large scatter, more than a factor of 2, when dynamic and static tests are not separated. Testing in a laboratory, in air as opposed to in deep water, results in the rams accelerating and hitting the drill pipe at speed, resulting in a dynamic test.

Dynamic tests (ram has a chance to accelerate prior to impacting the pipe) always indicate a much lower required shear force and account for virtually all of the data scatter. Static tests, where the rams approach the pipe to be sheared slowly give a well-defined upper bound shear force that is easily calculated. Further, in emergency situations, a static or slow shear is likely as the hydraulics may be compromised and/or being powered by an ROV which is incapable of dynamically accelerating a shear ram in use. The shearing will be slow and essentially static.

Using shear data in the open literature, a well-defined upper bound of shear force can be calculated. The calculated shear load, L_s , is:

¹² West Engineering Services, *Mini Shear Study* for U.S. Minerals Management Service, Requisition No. 2-1011-1003, December 2002.

$$L_s = 0.62 A_{dp} \sigma_f SF \quad (5)$$

where A_{dp} is the drill pipe cross sectional area, and σ_f is the flow stress equal to the specified minimum yield stress, σ_y , plus 10 *ksi*. For the most common deep water drill pipe, and that being used on the Deepwater Horizon, S-135, the flow stress defined in this manner is equal the specified minimum tensile strength, 145 *ksi*. An additional safety factor, SF , for design is also included in the formula (set equal to 1 for plotting in Fig 2). The shear constant was assumed to equal 0.62 based on the average ratio of shear ultimate stress to tensile ultimate stress in tests of high strength steels in fixtures.¹³ In shear strength measurement testing there is always some bending and local variations in stress present, therefore the shear stress is best characterized as the average shear stress across a section.¹⁴ This may also account for some of the older data in the literature reporting shear ultimate to tensile ultimate strength ratios as high as 0.75 some for steels.^{15,16}

With an Equation for required shear load, a corresponding required hydraulic pressure needed in a blind shear ram (BSR), P_{hyd} , can be determined with Equation 6:

$$P_{hyd} = \{L_s/A_{pist} + (P_w/C_r)\} SF \quad (6)$$

where A_{pist} is the effective cross sectional area of the BSR pistons, P_w is the well pressure relative to the pressure outside the BSR, and C_r is the closure ratio.

¹³ Guide to Design Criteria for Bolted and Riveted Joints, 2nd Edition (9780471837916): Geoffrey L. Kulak, John W. Fisher, John H. A. Struik, Wiley-Interscience; 1987.

¹⁴ Machine Design: Theory and Practice, Aaron D. Deutschman (Author), Walter J. Michels (Author), Charles E. Wilson, Prentice Hall; 1st Edition (April 11, 1975).

¹⁵ Machine design Theory and Practice, A.D. Deutschman, W.A Michels & C.E. Wilson, MacMillan Publishing 1975.

¹⁶ Stevick, G.R., Proposed Revision to Para. 302.3.1(b) Shear and Bearing Allowable Stress Basis, Correspondence to the ASME Piping Code Mechanical Design Committee Members, August 8, 2011.

Figure 3 shows Equation 5 (red line) with all the available data on high strength drill pipe (specification S-135), similar to that used by the DWH at Macondo:

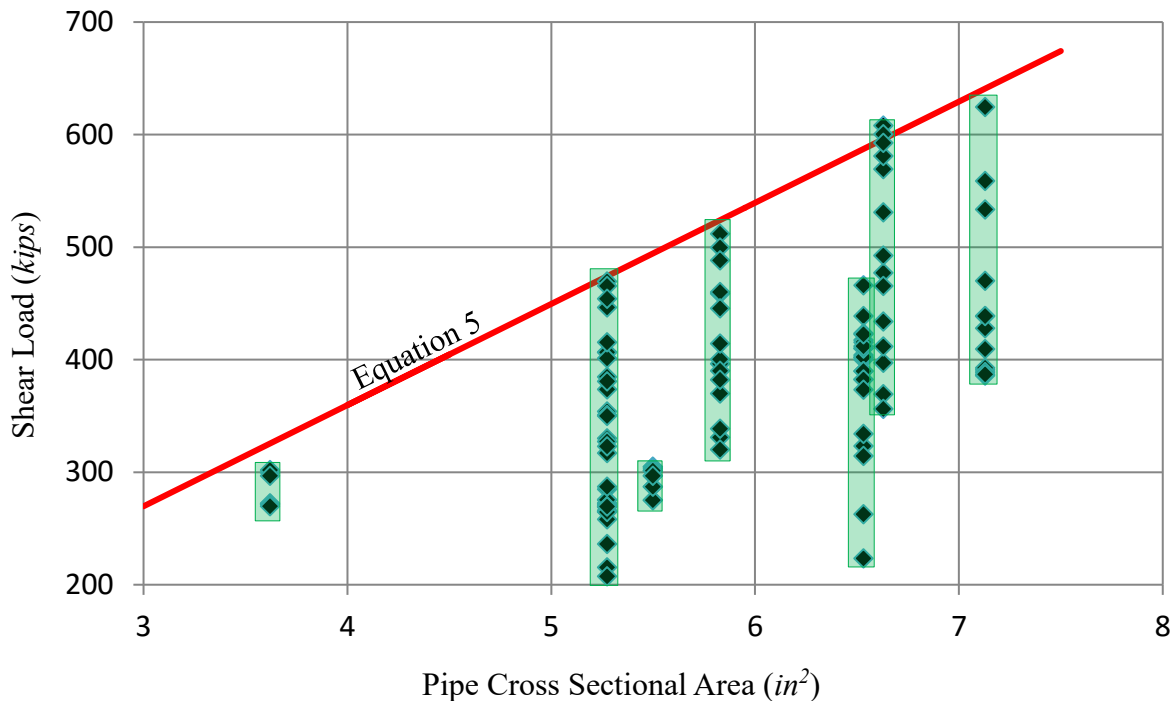

Figure 3. Shear force as a function of drill pipe cross sectional area. The test data is shown as black diamonds. Equation 5 is shown by the red line.

In the author's experience, it is customary for oil company engineers to perform verification calculations for shear rams.

However, considering that the drill string shear strength could vary as high as 0.75 times the ultimate tensile strength and blades can be dull or damaged, a reasonable safety factor should be applied to account for unknown variations. With reasonably accurate calculations of an upper bound shear force, an additional safety factor of at least 1.3¹⁷ should be included in a proper design.

¹⁷ Norton, R.L., Machine Design, an Integrated Approach, Prentice-Hall, 1998.

Additional margin can be easily been gained by installing: (i) double-V blades and/or (ii) dual or tandem pistons. Older BSR's typically have one straight blade and one V-shaped blade. Testing by West Engineering Services in 2004 for MMS indicates that double-V blades lower the required shear force, and therefore required hydraulic pressure, by a factor of approximately 15-20%.¹⁸

Tandem boosters are effectively two pistons on each side acting through the same piston rod as shown in Figure 4 below. Together they (double-V blades and tandem boosters) double the shear force for the same applied hydraulic pressure.

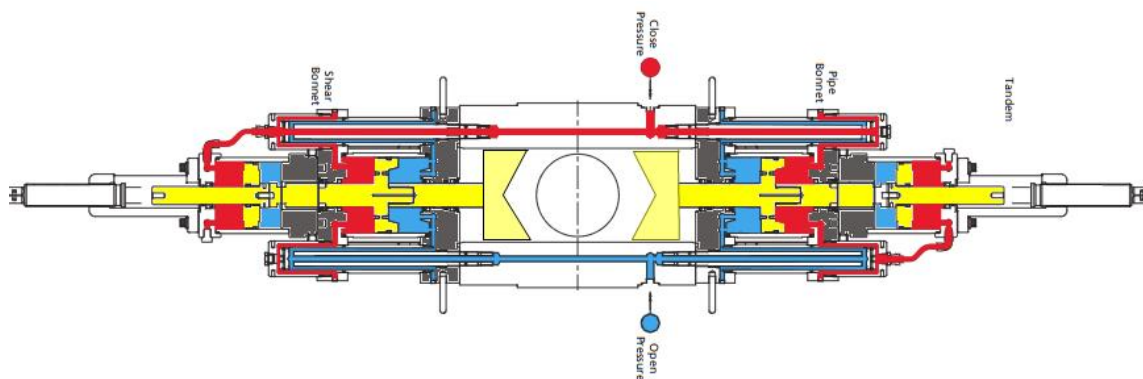

Figure 4. Cross sectional schematic of a tandem booster shear ram with double-V blades, hydraulic fluid in red and pistons, rods and rams in yellow.

The range of mixed mode data and plotting that has caused much of the confusion is shown in Figure 5 below from the 2004 MMS report by West Engineering:⁶

¹⁸ West Engineering Services, *Shear Ram Capabilities Study* for U.S. Minerals Management Service, Requisition No. 3-4025-1001, September 2004.

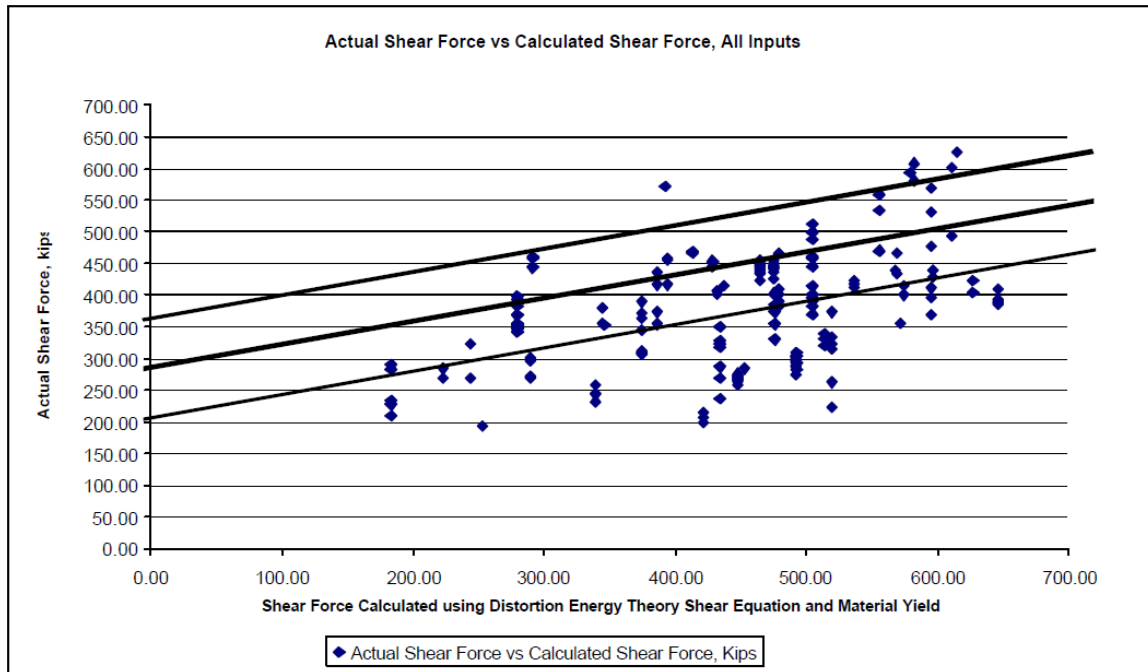

Figure 5. Graph 5.14 in Reference 17 attempting to correlate actual and calculated shear forces using all of the mixed mode data instead of shear load as a function of drill pipe area for static loading.

It is clear that the data is from a mixture loading modes, static and varying degrees of dynamic participation. Note, despite the mixture of loading modes, the authors attempt to apply a single set of statistics and derive a design loads based on the standard deviation. The result is barely useful as evidenced in the report’s conclusions: *“As can be seen, the data represents a pattern of shearing that does not fit a normal distribution but is similar to that of a normal distribution.”*

Taking a more rational approach, BEAR recommends using the upper bound of the mixed loading mode data until more appropriate static test data is developed. In either case, engineers will find Equation 5 to be more than adequate when used with a reasonable safety factor, 1.3 as a minimum, 1.5 preferred. Figure 3 is reproduced below as Figure 6 with Equation 5 (red line), Equation 5 with a safety factor of 1.3 (blue line) and Equation 5 with a safety factor of 1.5 (green line).

Requiring a safety factor of 1.3 to 1.5 is not excessive considering a safety factor of 3-4 is typically used in engineering design codes for pressure containing pipes and vessels. These same codes would have been used to design the pressure vessels and piping on the DWH itself.

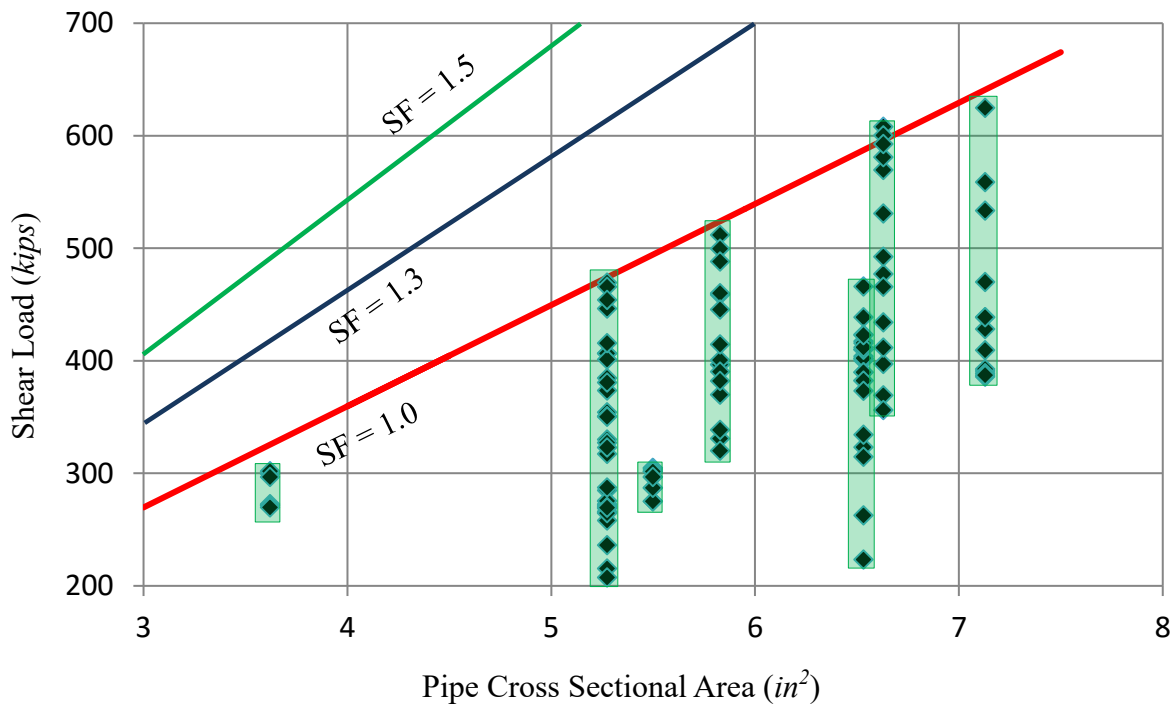

Figure 6. Shear force as a function of drill pipe cross sectional area. The test data is shown as black diamonds. Equation 1 is shown with safety factors of 1.0, 1.3 and 1.5 by the red, blue and green lines, respectively.

The data shown in Figure 6 and conclusion of mixed mode loading is also consistent with a statistical assessment performed by Hydril.¹⁹ In that assessment, 5.5 inch S-135 pipe with a cross sectional area of 5.83 in^2 , resulted in a static (slow) shear force of 512 kips.

¹⁹ The New Weibull Handbook, 2nd Edition, Authored and Published by Dr. Robert B. Abernethy, 1996. Case Study 9.7: Shear Ram Blowout Preventer Tests, contributed by Kenneth Young, Hydril Company, Houston, TX.

SHEAR RAM FRICTION

In addition to the forces required to shear drill pipe that might be in the well at the time of a blowout, the rams must also be able to overcome the frictional forces between the rams and BOP body. When a blowout occurs, these forces can be significant as the rams approach closure because there is a significant net pressure from the below acting on the rams. These frictional forces almost certainly played a role in the Hercules blowout that occurred July 23, 2013 in the Gulf of Mexico.²⁰ Additional research is needed to assess these forces.

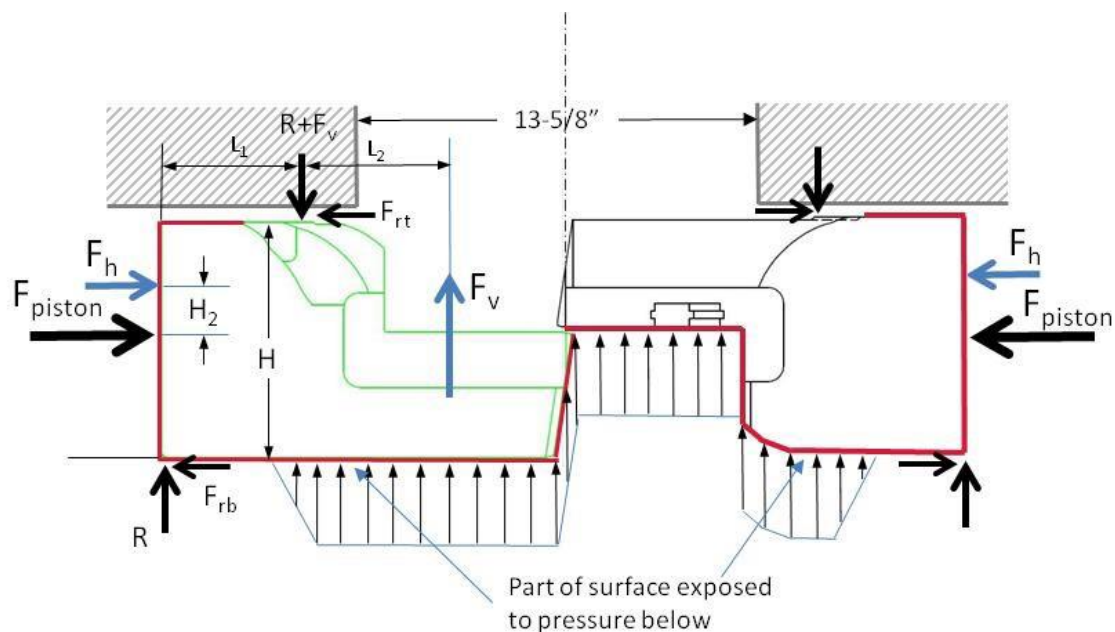

Figure 7. Net vertical load on the BSR blades causes additional frictional forces

CONCLUSIONS

Buckling and shearing considerations are now well understood and should be incorporated into BOP designs and risk assessments. Ram frictional forces are still unknown, however, additional safety factors can be rationally included to cover for this unknown.

²⁰ https://www.bsee.gov/sites/bsee_prod.opengov.ibmcloud.com/files/southtimbalier-220-panel-report9-8-2015.pdf.